

Varenummer: 0110047
 Beskrivelse: Seeger låsering JS 30X1,5
 Fjederstål

Mål

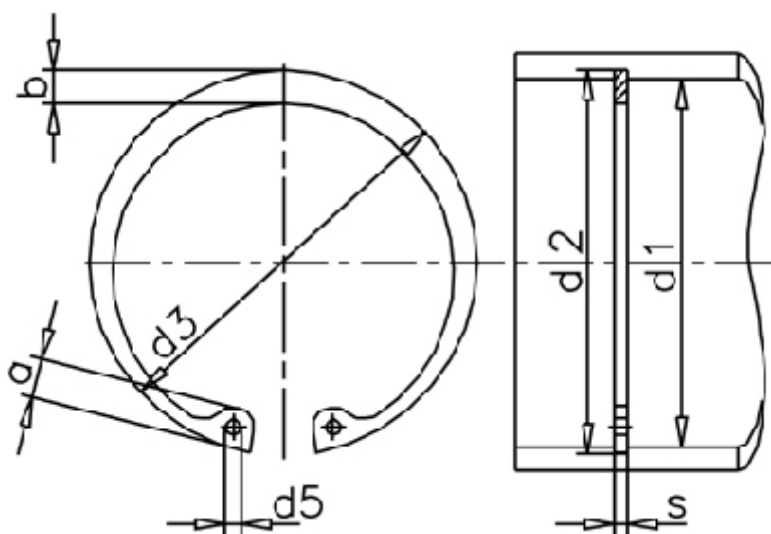

a max	= 5.5	d5 min	= 2.0	t	= 0.70
AN mm ²	= 67	FN kN	= 11.3	Tang	= ZGJ-2
B	= 1.56	FRg kN	= 7.2	tol	= 0.25
b	= 3.3	FR kN	= 21.4	tol	= +0,50 -0,25
Betegnelse	= JS 30	g	= 1.0	tol	= -0.06
d1	= 30	m min	= 1.60	vægt kg/1000	= 2.7
d2	= 31.4	Nominel træk	= 2.1		
d3	= 32.1	s	= 1.50		